

Clarke®



TILE VIBRATOR MODEL NO: C20VTV

PART NO: 3400517

OPERATION & MAINTENANCE INSTRUCTIONS

UK
CA | CE



ORIGINAL INSTRUCTIONS

GC 08/24

INTRODUCTION

Thank you for purchasing this CLARKE product.

Before attempting to use this product, please read this manual thoroughly and follow the instructions carefully. In doing so you will ensure the safety of yourself and that of others around you, and you can look forward to your purchase giving you long and satisfactory service.

This product has been designed to give long and trouble free service. If, however, having followed the instructions in this booklet carefully, you encounter problems take the product to your local CLARKE dealer.

GUARANTEE

This product is guaranteed against faulty manufacture for a period of 12 months from the date of purchase. Please keep your receipt which will be required as proof of purchase.

This guarantee is invalid if the product is found to have been abused or tampered with in any way, or not used for the purpose for which it was intended.

Faulty goods should be returned to their place of purchase, no product can be returned to us without prior permission.

This guarantee does not effect your statutory rights.

ENVIRONMENTAL RECYCLING POLICY



Through purchase of this product, the customer is taking on the obligation to deal with the WEEE in accordance with the WEEE regulations in relation to the treatment, recycling & recovery and environmentally sound disposal of the WEEE.

In effect, this means that this product must not be disposed of with general household waste. It must be disposed of according to the laws governing Waste Electrical and Electronic Equipment (WEEE) at a recognised disposal facility.

If disposing of this product or any damaged components, do not dispose of with general waste. This product contains valuable raw materials. Metal products should be taken to your local civic amenity site for recycling of metal products.

GENERAL POWER TOOL SAFETY WARNINGS



WARNING: READ ALL SAFETY WARNINGS AND ALL INSTRUCTIONS. FAILURE TO FOLLOW THE WARNINGS AND INSTRUCTIONS MAY RESULT IN ELECTRIC SHOCK, FIRE AND/OR SERIOUS INJURY.

Save these instructions for future reference.

WORK AREA SAFETY

1. **Keep work area clean and well lit.** Cluttered or dark areas invite accidents.
2. **DO NOT operate power tools in explosive atmospheres, such as in the presence of flammable liquids, gases or dust.** Power tools create sparks which may ignite the dust or fumes.
3. **Keep children and bystanders away while operating a power tool.** Distractions can cause you to lose control.

ELECTRICAL SAFETY

1. **Power tool plugs must match the outlet. NEVER modify the plug in any way. Do not use any adapter plugs with earthed (grounded) power tools.** Unmodified plugs and matching outlets will reduce risk of electric shock.
2. **DO NOT expose power tools to rain or wet conditions.** Water entering a power tool will increase the risk of electric shock.
3. **DO NOT abuse the charger power cable. NEVER use the cable for carrying, pulling or unplugging the charger. Keep the cable away from heat, oil, sharp edges or moving parts.** Damaged or entangled cables increase the risk of electric shock.

PERSONAL SAFETY

1. **Stay alert, watch what you are doing and use common sense when operating a power tool. DO NOT use a power tool while you are tired or under the influence of drugs, alcohol or medication.** A moment of inattention while operating power tools may result in serious personal injury.
2. **Prevent unintentional starting. Ensure the switch is in the off position before connecting to power source, picking up or carrying the tool.** Carrying power tools with your finger on the switch or energising power tools that have the switch on invites accidents.
3. **DO NOT overreach. Keep proper footing and balance at all times.** This enables better control of the power tool in unexpected situations.

4. **Dress properly. DO NOT wear loose clothing or jewellery. Keep your hair, clothing and gloves away from moving parts.** Loose clothes, jewellery or long hair can be caught in moving parts.

POWER TOOL USE AND CARE

1. **DO NOT force the power tool. Use the correct power tool for your application.** The correct power tool will do the job better and safer at the rate for which it was designed.
2. **DO NOT use the power tool if the switch does not turn it on and off.** Any power tool that cannot be controlled with the switch is dangerous and must be repaired.
3. **Disconnect the plug from the power source and/or the battery pack from the power tool before making any adjustments, changing accessories, or storing power tools.** Such preventive safety measures reduce the risk of starting the power tool accidentally.
4. **Store idle power tools out of the reach of children and do not allow persons unfamiliar with the power tool or these instructions to operate the power tool.** Power tools are dangerous in the hands of untrained users.
5. **Maintain power tools. Check for breakage of parts and any other condition that may affect the tool's operation. If damaged, have the tool repaired before use.** Many accidents are caused by poorly maintained power tools.
6. **Use the power tool in accordance with these instructions, taking into account the working conditions and the work to be performed.** Use of the power tool for operations different from those intended could result in a hazardous situation.

BATTERY TOOL USE AND CARE

1. **Recharge only with the charger specified by the manufacturer.** A charger that is suitable for one type of battery pack may create a risk of fire when used with another battery pack.
2. **Use power tools only with specifically designated battery packs.** Use of any other battery packs may create a risk of injury and fire.
3. **When battery pack is not in use, keep it away from other metal objects,** like paper clips, coins, keys, nails, screws or other small metal objects, that can make a connection from one terminal to another. Shorting the battery terminals together may cause burns or a fire.
4. **Under abusive conditions, liquid may be lost from the battery;** avoid contact. If contact accidentally occurs, flush with water. If liquid contacts eyes, additionally seek medical help. Liquid ejected from the battery may cause irritation or burns.

HAND/ARM VIBRATION

Employers are advised to refer to the HSE publication "Guide for Employers".

All hand held power tools vibrate to some extent, and this vibration is transmitted to the operator via the handle or hand used to steady the tool. Vibration from about 2 to 1500 herz is potentially damaging and is most hazardous in the range from about 5 to 20 herz.









Operators who are regularly exposed to vibration may suffer from Hand Arm Vibration Syndrome (HAVS), which includes 'dead hand', 'dead finger', and 'white finger'. These are painful conditions and are widespread in industries where vibrating tools are used.

The health risk depends upon the vibration level and the length of time of exposure to it, in effect, a daily vibration dose.

WARNING: THIS TILE VIBRATOR SHOULD ONLY BE USED FOR A MAXIMUM OF 16 MINUTES BEFORE REACHING THE HAND-ARM VIBRATION EXPOSURE LIMIT.

SAFETY SYMBOLS

The following safety symbols may be found on this product.

	Read instruction manual before use		Weee Symbol (lithium ion batteries)
	Do not immerse batteries in water		Do not Incinerate batteries
	Wear eye protection		Wear ear protection
	Wear dust protection		Wear hand protection

ELECTRICAL CONNECTIONS



WARNING: READ THESE ELECTRICAL SAFETY INSTRUCTIONS THOROUGHLY BEFORE CONNECTING THE PRODUCT TO THE MAINS SUPPLY.

The battery charger is provided with a standard 13 amp, 230 volt (50Hz), BS 1363 plug, for connection to a standard, domestic electrical supply. Should the plug need changing at any time, ensure that a plug of identical specification is used.



**WARNING: THE WIRES IN THE POWER CABLE OF THIS PRODUCT ARE COLOURED IN ACCORDANCE WITH THE FOLLOWING CODE:
BLUE = NEUTRAL BROWN = LIVE**

If the colours of the wires in the power cable of this product do not correspond with the markings on the terminals of your plug, proceed as follows.

- The wire which is coloured **Blue** must be connected to the terminal which is marked **N** or coloured **Black**.
- The wire which is coloured **Brown** must be connected to the terminal which is marked **L** or coloured **Red**.

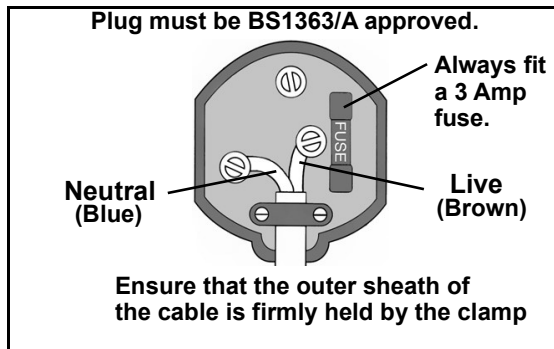

We strongly recommend that this machine is connected to the mains supply via a Residual Current Device (RCD).

If in any doubt, consult a qualified electrician. DO NOT attempt any repairs yourself.



This symbol indicates that this is a Class II product, and does not require an earth connection.

OVERVIEW

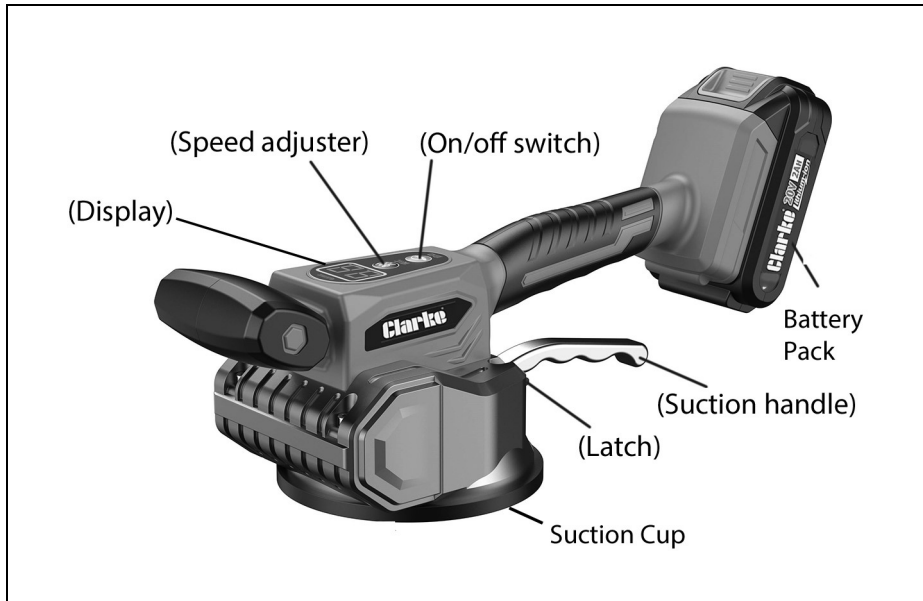

The following items should be supplied in the carton. If any parts are missing or damaged this should be reported to your CLARKE dealer where the machine was originally purchased.

- 18 Volt Tile Vibrator
- Battery Charger
- Li-Ion Battery Packs
- Blow Moulded Case

BATTERY CHARGING



WARNING: WHEN THE BATTERY IS REMOVED FROM THE MACHINE AFTER USE, IT MAY BE HOT. ALWAYS ALLOW IT TO COOL BEFORE RECHARGING. DO NOT RECHARGE A HOT BATTERY.

- The battery pack must be charged before operating the machine.
- The battery should be charged at ambient air temperatures of between -10°C and 45°C.

To charge the battery pack, proceed as follows.

1. Connect the charger to the mains supply.
 - The green power indicator will light up.
2. Slide the battery onto the battery charger.
 - The green power indicator will go off and the red charging LED will illuminate while charging is in progress.
3. Check the battery status by pressing the BATTERY symbol. The status will be indicated by the three LEDs showing 25%, 50% and 100% charged.
 - When the battery is fully charged the green LED will be on.
 - If both LEDs are flashing rapidly the battery pack has become too hot or is defective.
4. Switch off the charger at the mains and remove the battery.

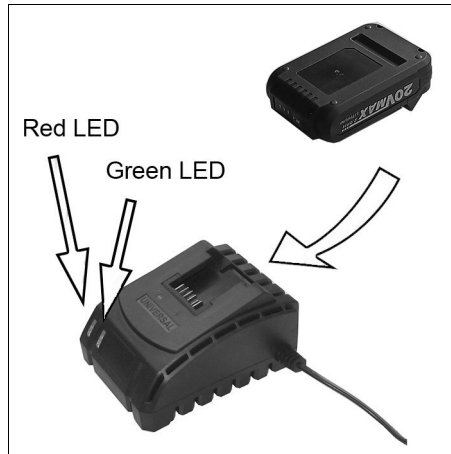

NOTE: Whilst charging, the battery pack and charger may become warm. This is normal and can be expected.

BEFORE USE

FITTING AND REMOVING THE BATTERY

1. Slide the battery pack onto the base of the handle until it clicks into place.
2. To remove, press and hold the release button on the battery and slide it away from the base of the handle.



OPERATION

Tiles and panels up to 23kg can be lifted and placed in position using the suction cup feature.

CAUTION: DO NOT ATTEMPT TO LIFT TILES HEAVIER THAN SPECIFIED.

1. Lock the vibrator onto the tile to be laid by pressing down and lifting the suction handle to achieve suction. When it has latched onto the tile, the handle can be locked in place. To release, raise the latch and the handle can drop back down to relinquish suction.
2. Start the tile vibrator using the ON/OFF button and adjust the speed up or down by pressing the forward speed control button.
 - The speed will be displayed in increments of 0 to 12 by the digital display.
3. Hold the machine firmly with both hands and move steadily around the tile, applying a light even pressure.



WARNING: THIS TILE VIBRATOR SHOULD ONLY BE USED FOR A MAXIMUM OF 16 MINUTES BEFORE REACHING THE HAND-ARM VIBRATION EXPOSURE LIMIT.

CARE AND MAINTENANCE



WARNING: ALWAYS REMOVE THE BATTERY PACK BEFORE CLEANING

1. Clean the machine with a soft cloth.
 - Avoid using solvents when cleaning plastic parts, (most plastics are susceptible to damage from the various types of commercial solvents)
2. Check the power cable of charger to ensure it is sound and free from cracks, bare wires etc.
3. There are no user serviceable parts inside the machine. Refer to your CLARKE dealer if internal maintenance is required.

FAULTFINDING

Problem	Possible Cause	Remedy
Tool will not operate.	Battery discharged.	Check battery is charged and rectify as necessary.
	Faulty switch.	Consult your CLARKE dealer.
	Fuse blown in charger.	Replace fuse as on page 6.
	Faulty motor.	Consult your CLARKE dealer.
Motor runs but pad does not vibrate.	Eccentric cam loose.	Consult your CLARKE dealer.
Motor becomes hot.	Unduly heavy use.	Reduce the force applied to the machine. Let the machine do the work.

SPECIFICATIONS

Item	Specification
Dimensions (L x W x H)	325 x 123 x 155 mm
Weight	1.34kg + 400g Battery = 1.74kg
Suction Cup Diameter	123 mm
Operating modes	1-12 vibration settings
Vibration rate	3500-8500 bpm
Maximum lift capacity	23kg
Battery life	Approx 1 hour (max speed)
Charging time (from flat)	Approx 1 hour
Charger Operating voltage	230V ~ 50 Hz
Battery Voltage	18.5V nominal
IP rating	IPX0
Duty cycle	S1-continuous
Charger Fuse Rating	3 A
No Load Motor Speed	10600 rpm
Sound Pressure Level dB LpA	90.3 dB
Sound Power Level dB LWA	98.3 dB
Guaranteed Sound Power Level dB LWA	101 dB
Uncertainty factor	3 dB
Vibration (handle)	26.7 m/s ²
Uncertainty factor	1.5 m/s ²

Please note that the details and specifications contained herein, are correct at the time of going to print. However, CLARKE International reserve the right to change specifications at any time without prior notice.

COMPONENT PARTS DIAGRAM

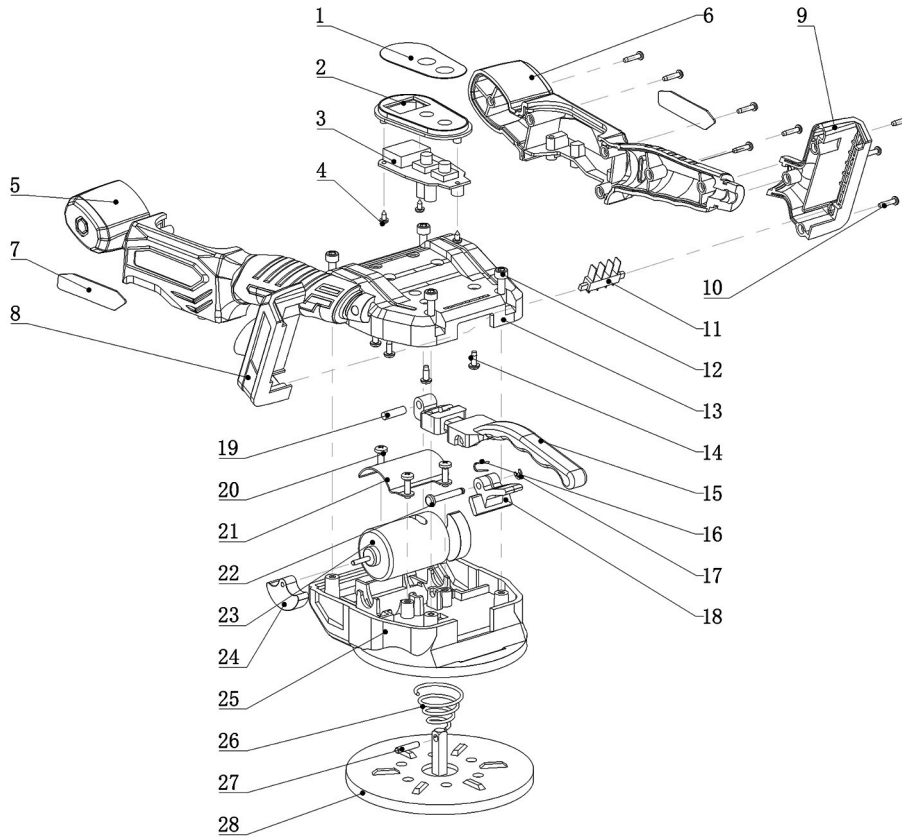

COMPONENT PARTS LIST

No	Description	No	Description
1	Sticker	15	Locking lever
2	Transparent cover plate	16	Spring
3	Circuit board	17	Circlip 3 x 7
4	Self tapping screw M2 x 6	18	Locking lever cam
5	Left housing	19	Hinge pin 5 x 17
6	Right housing	20	Screw M4 x 12
7	Label	21	Motor cover
8	Left battery housing	22	Hinge pin 4 x 27
9	Right battery housing	23	Motor
10	Self tapping screw M3 x 10	24	Eccentric weight
11	Battery connector	25	Aluminium base
12	Hex socket screw M4 x 15	26	Spring
13	Aluminium cover	27	Pin 4 x 18
14	Self tapping screw M4 x 12	28	Suction cup

DECLARATION OF CONFORMITY - UK



Clarke[®]
INTERNATIONAL

Hemnall Street, Epping, Essex, CM16 4LG

DECLARATION OF CONFORMITY

This is an important document and should be retained.

We hereby declare that this product(s) complies with the following legislation:

The Batteries and Accumulators (Placing on the Market) Regulations 2008

The Electromagnetic Compatibility Regulations 2016

The Supply of Machinery (Safety) Regulations 2008

The Restriction of the Use of Certain Hazardous Substances in Electrical and Electronic Equipment Regulations 2012

The following standards have been applied to the product(s):

*EN 60335-1:2012+A11:2014+A13:2017+A1:2019+A14:2019+A2:2019+A15:2021, EN 62841-1:2015/A11:2022,
EN 61000-3-3:2013+A1:2019+A2:2021, EN IEC 61000-3-2:2019+A1:2021, EN ISO 12100:2010, EN 62233:2008,
EN 60335-2-29:2021+A1:2021, EN 62321-7-1:2015, EN 62321-7-2:2017, EN 62321-3-1:2014, EN 62321-8:2017,
EN IEC 55014-1:2021, EN IEC 55014-2:2021, EN 62321-5:2014, EN 62321-6:2015, EN 62321-4:2014/A1:2017,
EN IEC 62321-2:2021, EN 62321-1:2013*

The technical documentation required to demonstrate that the product(s) meet(s) the requirement(s) of the aforementioned legislation has been compiled and is available for inspection by the relevant enforcement authorities.

The UKCA mark was first applied in: 2024

Product Description: Tile Vibrator
Model Number(s): C20VTV
Serial/Batch Number: Refer to product/packaging label
Date of Issue: 07/05/2024

Signed:

J.A Clarke

Director

DECLARATION OF CONFORMITY - CE



Clarke[®]
INTERNATIONAL

Fitzwilliam Hall, Fitzwilliam Place, Dublin 2

DECLARATION OF CONFORMITY

This is an important document and should be retained.

We hereby declare that this product(s) complies with the following legislation:

2006/66/EC	Battery Directive
2014/30/EU	Electromagnetic Compatibility Directive
2006/42/EC	Machinery Directive
2011/65/EU	Restriction of Hazardous Substances (RoHS) Directive

The following standards have been applied to the product(s):

EN 60335-1:2012+A11:2014+A13:2017+A1:2019+A14:2019+A2:2019+A15:2021, EN 62841-1:2015/A11:2022,
EN 61000-3-3:2013+A1:2019+A2:2021, EN IEC 61000-3-2:2019+A1:2021, EN ISO 12100:2010, EN 62233:2008,
EN 60335-2-29:2021+A1:2021, EN 62321-7-1:2015, EN 62321-7-2:2017, EN 62321-3-1:2014, EN 62321-8:2017,
EN IEC 55014-1:2021, EN IEC 55014-2:2021, EN 62321-5:2014, EN 62321-6:2015, EN 62321-4:2014/A1:2017,
EN IEC 62321-2:2021, EN 62321-1:2013

The technical documentation required to demonstrate that the product(s) meet(s) the requirement(s) of the aforementioned legislation has been compiled and is available for inspection by the relevant enforcement authorities.

The CE mark was first applied in: 2024

Product Description:	Tile Vibrator
Model Number(s):	C20VTV
Serial/Batch Number:	Refer to product/packaging label
Date of Issue:	07/05/2024

Signed:

J.A Clarke

Director

A SELECTION FROM THE VAST RANGE OF

Clarke®

QUALITY PRODUCTS



AIR COMPRESSORS

From DIY to industrial, Plus air tools, spray guns and accessories.

GENERATORS

Prime duty or emergency standby for business, home and leisure.

POWER WASHERS

Hot and cold, electric and engine driven - we have what you need

WELDERS

Mig, Arc, Tig and Spot. From DIY to auto/industrial.

METALWORKING

Drills, grinders and saws for DIY and professional use.

WOODWORKING

Saws, sanders, lathes, mortisers and dust extraction.

HYDRAULICS

Cranes, body repair kits, transmission jacks for all types of workshop use.

WATER PUMPS

Submersible, electric and engine driven for DIY, agriculture and industry.

POWER TOOLS

Angle grinders, cordless drill sets, saws and sanders.

STARTERS/CHARGERS

All sizes for car and commercial use.

PARTS & SERVICE: 0208 988 7400

Parts Enquiries

Parts@clarkeinternational.com

Servicing & Technical Enquiries

Service@clarkeinternational.com

SALES: UK 01992 565333 or Export 00 44 (0)1992 565335

Clarke INTERNATIONAL Hemnall Street, Epping, Essex CM16 4LG
www.clarkeinternational.com